

NOTE:  
 1. Design and Manufacture for valve according to ASME B16.34.  
 2. Inspection and Test for valve according to API 598.  
 3. The connection of screwed for valve according to ANSI B1.20.1.

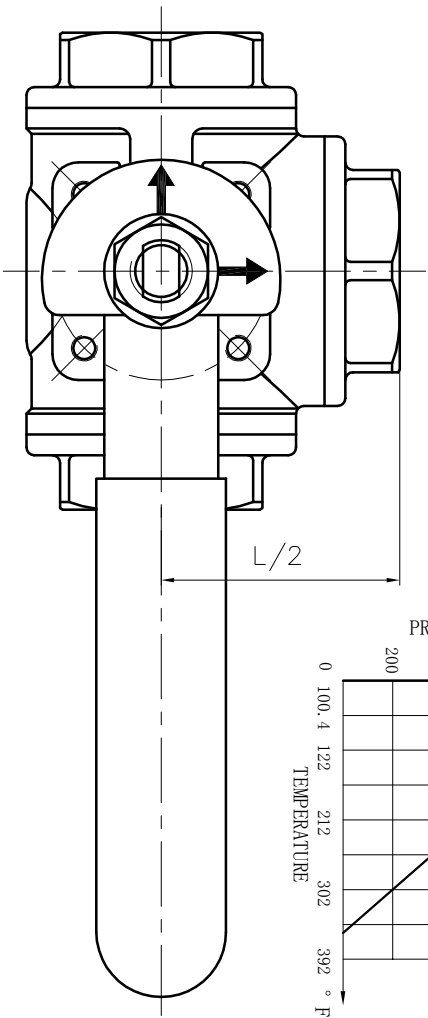
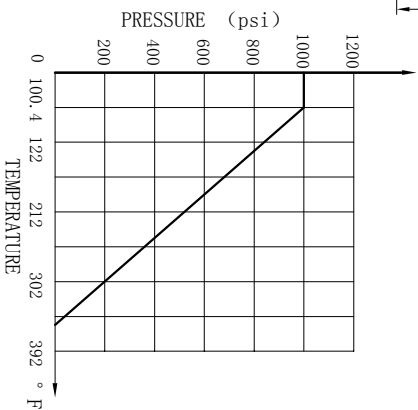

Nominal pressure			1000Psi			
Test pressure	Shell test	10.4	Test medium	Water	Test temperature	Normal temperature
	Seal test	7.6		Air		
Gas seal test	0.6		Water, Oil, Gas			
Applicable medium			-20~356°F			
Applicable temperature						

NPS	L	d	NPT	Lo	H	Weight (lb)
1/4"	2.795	0.394	1/4"	3.937	2.244	1.146
3/8"	2.795	0.394	3/8"	3.937	2.244	1.102
1/2"	2.913	0.472	1/2"	4.331	2.303	1.268
3/4"	3.465	0.591	3/4"	4.724	2.362	1.962
1"	3.622	0.787	1"	5.512	2.835	2.646
1 1/4"	4.882	0.984	1 1/4"	5.512	3.228	5.137
1 1/2"	5.433	1.260	1 1/2"	7.087	3.740	7.871
2"	6.063	1.496	2"	7.874	3.937	9.921

13	INDICATOR BOARD	1	304			
12	NUT	1	A194 8			
11	WASHER	1	304			
10	HANDLE	1	STAINLESS STEEL			
9	GLAND	1	304			
8	PACKING	1	RPTFE			
7	STEM WASHER	1	RPTFE			
6	STEM	1	A276 316			
5	BODY	1	A351 CF8M			
4	BALL	1	SS316			
3	SEAT	4	RPTFE			
2	GASKET	3	RPTFE			
1	BONNET	3	A351 CF8M			
NO.	DESCRIPTION	Q'TY	MATERIAL			
			<b>ANIX®</b>			
			ANIX VALVE USA			
			3 Way L Port			
			Ball Valve 1000PSI, NPT			
			BV14R6N/1000			
MARK	BEFORE MODIFIED	AFTER MODIFIED	DATE	SCALE		
DRA.		APP.				
CHK.		DATE				