

Installation, Operation, and Maintenance (IOM) Manual for Ball Valve with Deadman Spring Return Handle

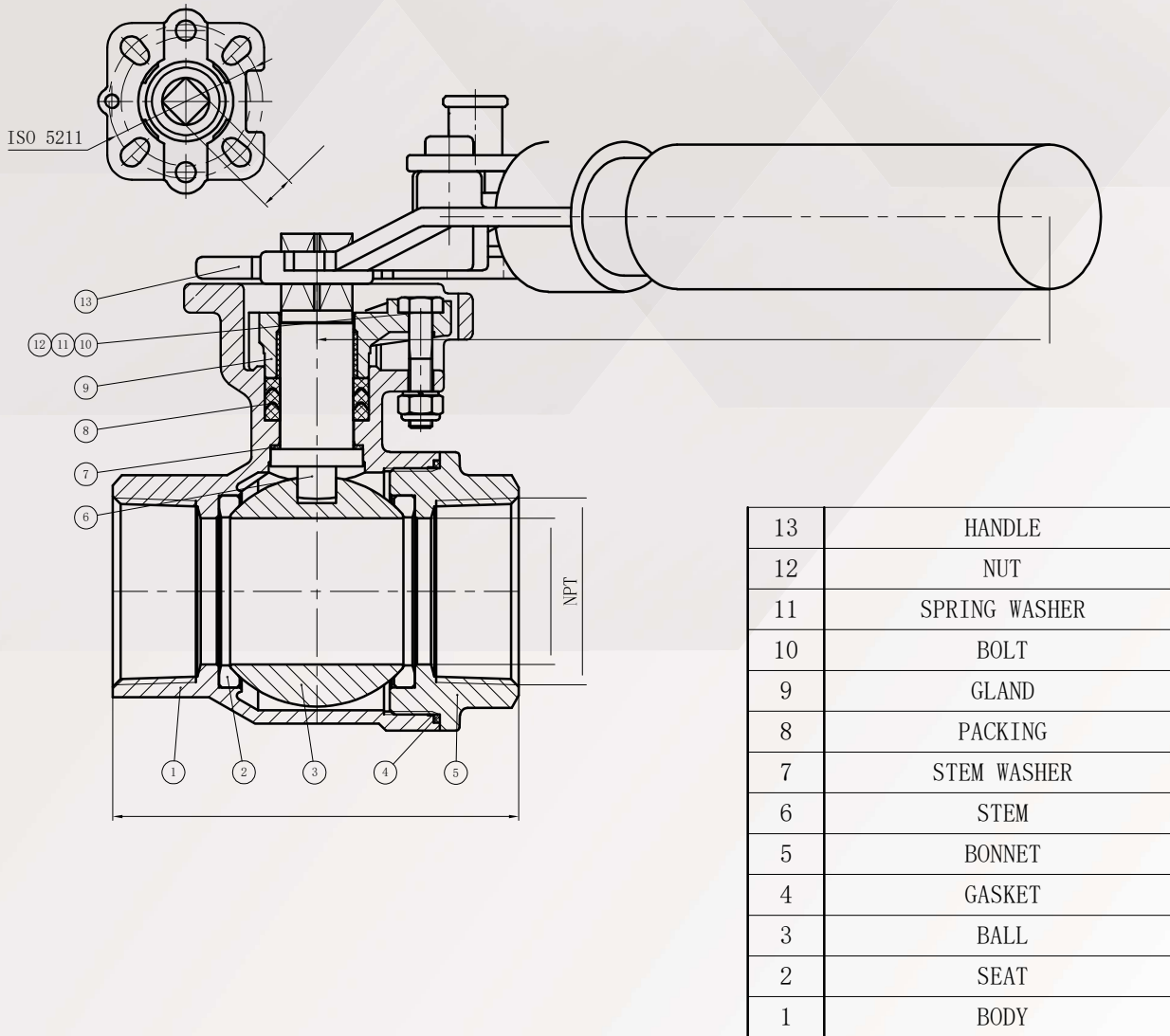

Refer to the diagram and parts list above for a detailed view of each component, assisting with installation, operation, and maintenance for optimal valve performance.



ANIX VALVE CO.LTD, Certified ISO 9001.

www.anixusa.com

Note: This document is a general guideline for the installation, operation, and maintenance of Ball Valves with Deadman Handle, intended to assist trained personnel in following recommended procedures. It is not an exhaustive set of instructions. Carefully read the manual for safe and efficient use. We are not liable for damages arising from its use. Consult a professional if you have specific concerns related to your application or environment. For additional assistance, contact your supplier or representative.

PRODUCT OVERVIEW

- This ball valve features a deadman handle designed to automatically return to a closed or predetermined position when released, ensuring enhanced safety and control. The valve operates by rotating a ball within the valve body to start, stop, or regulate flow through the pipeline. Compact and lightweight, the valve is easy to seal with PTFE material and provides reliable performance for a variety of applications.
 - Do not attempt any maintenance on the valve while it is under pressure.
 - Ensure all components are free of residual media before disassembly.

INSTALLATION

- **Orientation:**
 - The valve may be installed in any orientation within the pipeline. Ensure compatibility with ASME B31 standards and account for potential pipeline or media expansion/contraction.



ANIX[®]

ANIX VALVE CO.LTD, Certified ISO 9001.
www.anixusa.com

• Threaded Connections:

- Ensure mating pipe connections are clean and free of foreign material.
- Apply 2–4 wraps of PTFE tape or a suitable pipe joint compound to the male threads. Avoid using both simultaneously.
- Use two wrenches during installation: one to hold the valve body near the pipe joint and the other to tighten the pipe. This prevents torque from being transmitted through the valve body.
- Tighten 1–1½ turns beyond hand-tight. Do not overtighten or reverse-rotate after installation, as this may damage the valve or its seals.

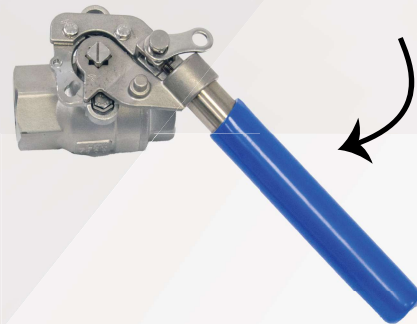

OPERATION

• Deadman Handle Usage:

- To open the valve, push the handle against the spring's resistance and rotate it
- To close the valve, release the handle, allowing the spring to return it to the closed position automatically.
- Ensure the valve is fully open when using the handle to provide the spring with adequate torque to return the handle fully closed upon release.
- Avoid partial open positions. This valve is designed for fully on/off use only.



ANIX[®]

ANIX VALVE CO.LTD, Certified ISO 9001.

www.anixusa.com

- **Locking Mechanism:**

- A locking mechanism is provided on top of the valve. Engage it to lock the valve in the desired position for extended operation or maintenance.

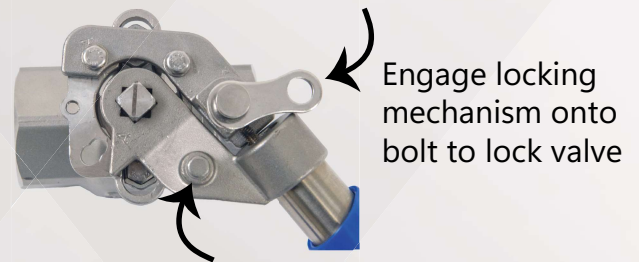

- **Safety Considerations:**

- Avoid standing directly in line with the stem axis while operating the valve.
- Do not apply excessive force to the handle. The spring mechanism ensures adequate torque for operation.

- **Stem Seal Adjustments**

- If leakage is observed around the stem packing area:
 - Tighten the stem nut in 1/8-turn increments until leakage stops.
 - If leakage persists after adjustments, replace the stem seals.

MAINTENANCE

- **Routine Maintenance:**

- Inspect the valve and handle mechanism periodically for wear or damage.
- Ensure the top screws, bolts, and nuts on the direct mounting pad that connect the handle to the pad are fully tightened and not loose.

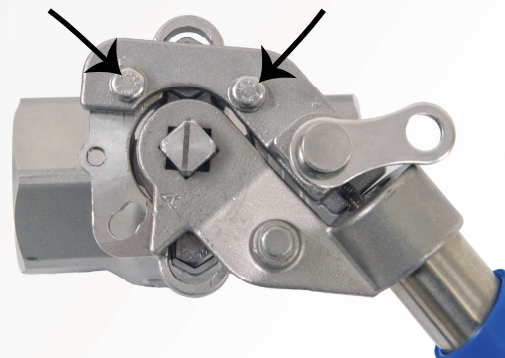

ANIX[®]

ANIX VALVE CO.LTD, Certified ISO 9001.
www.anixusa.com

- Verify that the handle itself is securely fastened. Turn the handle clockwise to ensure it is fully tightened.

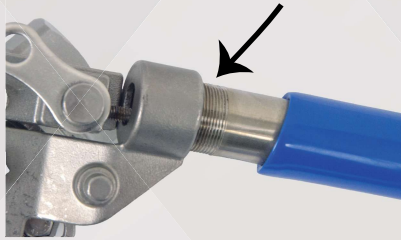

- Tighten the packing gland screw in small increments if stem leakage occurs.
- Ensure the spring and handle assembly move freely without obstruction.

• Handle Disassembly:

- Remove the handle by unscrewing the two bolts on the mounting pad.
- Unscrew the handle itself and inspect the washer and bolt at the end of the spring. Ensure both are firmly tightened to maintain spring tension.

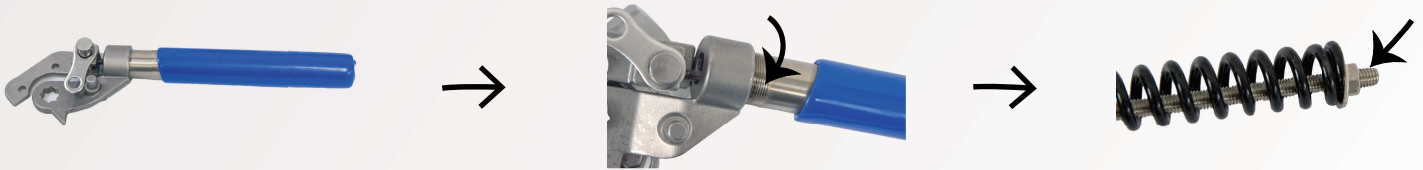
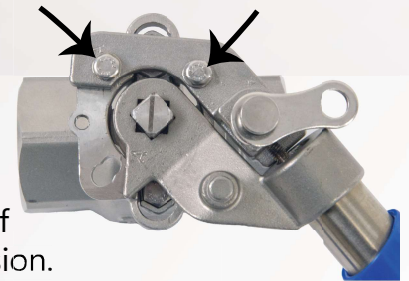

- Reassemble the handle by reversing the steps above. Apply a thread-locking compound to bolts if needed.

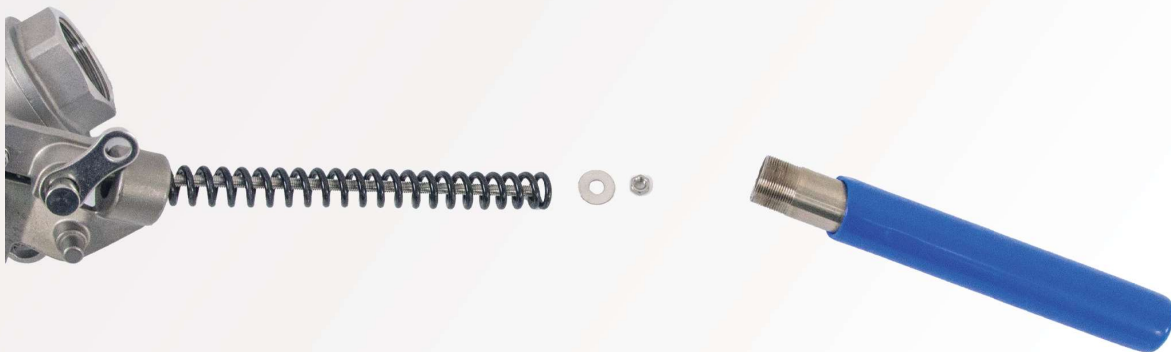



ANIX VALVE CO.LTD, Certified ISO 9001.
www.anixusa.com

- **Storage:**

- Store the valve in a clean, dry environment to prevent corrosion.
- For long-term storage, inspect periodically, clean as needed, and apply a rust-preventive coating if required.

- **Pre-Installation Check:**

- Verify that the valve markings, handle mechanism, and specifications match the application requirements.
- Check for any visible damage or debris.

- **DISCLAIMER:**

- This Installation, Operation, and Maintenance (IOM) document is primarily focused on the deadman handle's operation, maintenance, and related components. For detailed information on the specific ball valve body type, including materials, dimensions, and application-specific guidelines, please refer to the corresponding IOM & product literature for that ball valve model. This document is not intended to replace the standard IOM for the ball valve body itself.

