

3-Piece Body Ball Valve 1000# with Direct Mount Installation, Operation and Maintenance Instructions

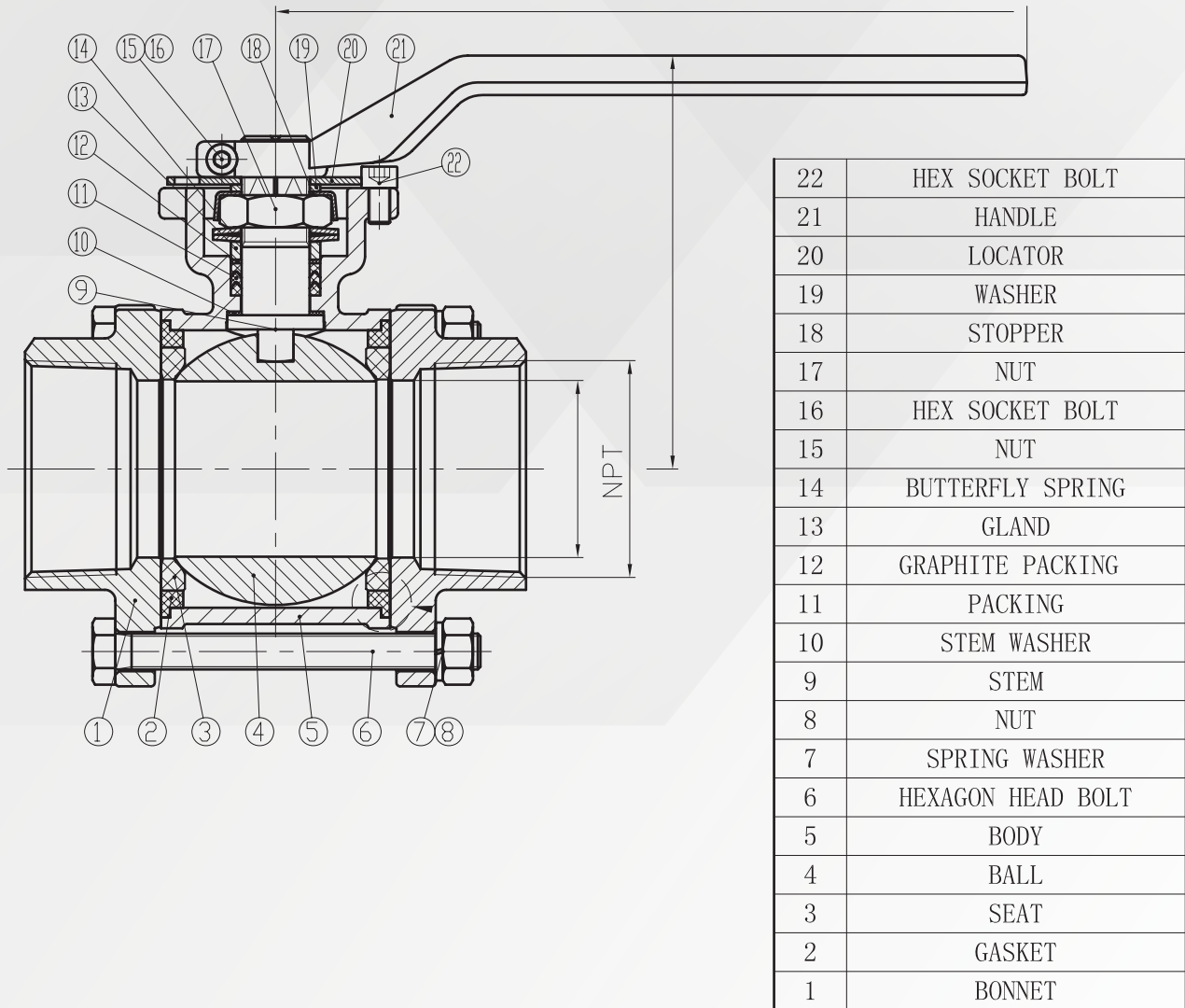

Refer to the diagram and parts list above for a detailed view of each component, assisting with installation, operation, and maintenance for optimal valve performance.

OVERVIEW

3-piece body ball valves are a type of quarter-turn valve that consists of three main components: two end pieces (also known as end caps) and a central body. This design allows for easy maintenance and replacement of internal components without having to remove the valve from the pipeline.



ANIX VALVE CO.LTD, Certified ISO 9001.

www.anixusa.com

STORAGE AND HANDLING

- **Storage Conditions:** Store valves in their original packaging until installation, keeping them dry and protected from environmental elements or potential damage. For long-term storage, inspect periodically, remove any dust or dirt, and apply a rust-preventive coating if needed.
- **Transportation:** Secure the valve during transport to avoid any potential damage to the valve or harm to personnel.

PRE-INSTALLATION

- **Specifications Check:** Ensure the valve's specifications match the application's pressure, temperature, and medium requirements.
- **Inspection:** Check that all components are present and undamaged, including seals and gaskets. Do not install if there are any signs of damage.
- **Pipeline Cleanliness:** Before installation, make sure the piping system is clear of construction debris, such as weld slag, sandblasting grit, and metal chips, which can damage valve seating surfaces.
- **Valve Position:** All valves are shipped in the open position to protect the ball surface. Avoid installing damaged valves.

INSTALLATION ORIENTATION

- **Correct Positioning:** Install the valve in a way that allows the actuator or control mechanism to be easily accessible and visible.
- **Installation Direction:** Valves can be installed in any orientation—upright, vertical, or horizontal, depending on operational requirements.
- **Quarter-Turn Operation:** For actuated operation, these ball valves feature a 90° rotation with a direct mounting pad for easy actuation:
 - To open the valve: Turn the actuator or handle to the designated open position.
 - To close the valve: Turn the actuator or handle to the designated closed position.



ANIX VALVE CO.LTD, Certified ISO 9001.
www.anixusa.com

INSTALLATION PROCEDURES

- **Threaded End Valves**
 - **Thread Sealant:** Apply a suitable joint compound or TFE (PTFE) tape to the pipe threads to ensure a leak-free joint.
 - **Wrench Use:** When tightening, use a wrench on the hexagonal part of the valve body, not on the handle, to prevent damage.
- **Welding End Valves (Socket Weld and Butt Weld)**
 - **Qualified Personnel:** Only personnel qualified per ASME BPVC Section IX should perform welding on pressure-containing components.
 - **Disassembly for Welding:** To protect internal components from heat damage, partially disassemble the valve:
 - Place the valve in the open position.
 - Remove body hex nuts, lock washers, and body hex bolts, then carefully detach the center section, keeping seat/seals in place.
 - **Heat Protection:** Wrap the valve center section with wet rags to limit heat transfer. Ensure the center section temperature does not exceed 400°F (204°C).
 - **Welding Process:** Align the valve with the piping system, tack-weld it into place, then complete the welding using small beads and cooling between passes. Reinstall the handle or actuator once cooled.
- **Post-Installation Check**
 - **Visual Inspection:** Inspect all connections for tightness, potential leaks, and alignment
 - **Functional Test:** Operate the actuator or control mechanism to verify it opens and closes smoothly.

Disclaimer: The information provided here is intended as a general guide for maintenance and installation procedures. These are suggestions and may not account for all specific conditions or applications. ANIX Valve is not liable for any damages, injuries, or malfunctions resulting from the use of these instructions.



ANIX VALVE CO.LTD, Certified ISO 9001.
www.anixusa.com

OPERATION

- **Quarter-Turn Mechanism:** The valve operates with a simple quarter-turn:
 - **Open Position:** The ball's port aligns with the flow path when fully open.
 - **Closed Position:** The ball blocks the flow completely when closed, creating a seal against the valve seats.
- **Smooth Operation:** During regular use, the valve should open and close smoothly without excessive force. Check for obstructions or misalignment if resistance is felt.
- **Routine Operation:** To maintain optimal performance, operate (open and close) the valve periodically, especially if not in frequent use, to prevent the seals from sticking or becoming damaged.
- **Monitoring and Emergency Shutdown:** Regularly check for leaks around the body, connections, and stem seal. Ensure the valve is accessible for emergency shutdown, with manual override capability for automated systems.

MAINTENANCE INSTRUCTIONS

- **Valve Adjustments**
 - **Stem Packing:** Adjusted at the factory, but over time, the stem packing may need tightening to maintain a leak-tight seal. Stem leakage should be stopped as soon as it is detected. On actuated valves, most mounting hardware allows access to the packing adjustment screws. If this is not the case, it may be necessary to remove the actuator to gain adequate access to make the packing adjustment.
 - If leakage occurs around the stem, tighten the stem nut by 1/8 turn at a time until the leak stops.
 - For actuated valves, adjust packing screws to the maximum torque specified in the manufacturer's torque tables.
 - **Important:** Never loosen the packing screws when the valve is under pressure.
- **Remove the Center Body Section**
 - Loosen and remove the body hex nuts, lock washers, and bolts.
 - Carefully detach the center section of the valve body from the end caps, ensuring you keep the valve in a stable, open position. This allows access to the internal components without disrupting the surrounding pipeline connections.



ANIX VALVE CO.LTD, Certified ISO 9001.
www.anixusa.com

Inspect and Replace Internal Components

- **Ball and Seats:** Inspect the ball and seats for wear or damage. Replace if necessary to maintain proper sealing.
- **Seals and Gaskets:** Check seals and gaskets around the stem and between the body and end caps. Replace any worn or damaged seals to prevent leaks.
- **Stem Packing:** Inspect the stem packing for wear and adjust or replace as needed.

Reassembly

- Carefully align the center body section back between the end caps, ensuring all seals and seats remain in place.
- Replace the bolts, lock washers, and nuts, and tighten them uniformly in a crisscross pattern to ensure an even seal.
- With the valve reassembled, test it by turning the handle through several open-close cycles, checking for smooth operation and ensuring no leaks.

Preventive Maintenance Schedule

- **Routine Checks:** For high-use applications, inspect every 5,000 cycles. Once the system stabilizes, perform checks every 20,000 cycles.
- **Maintenance Records:** Keep detailed records of installation, operation, and maintenance activities to track performance and valve history.

SAFETY PRECAUTIONS

- **Personnel Positioning:** Avoid standing directly in line with the stem axis to reduce injury risk.



ANIX VALVE CO.LTD, Certified ISO 9001.
www.anixusa.com

STORAGE AND LONG-TERM MAINTENANCE

- Protective Storage: Store valves in a dry location to prevent rust or environmental damage.
- Periodic Inspection: For long-term storage, periodically inspect and clean the valve, and apply rust-preventive coating if necessary to preserve functionality.

*****WARNING: Never attempt maintenance on pressurized valves. Ensure all pressure is released from the system before performing any maintenance.*****

